

VDO KIENZLE

Montage- und Bedienungsanleitung
Installation and Operating Instructions

VDO
Ocean Line

Wind



Installation and Operating Instructions
Page 22 - 40

Table of contents

Preface	24
Safety instructions	25
for installation	25
for maintenance	26
The VDO Ocean Line Wind	27
Components of the system	28
Accessories	28
Spare parts	28
Display functions of the VDO Ocean Line Wind anemometer system	29
Maintenance of the VDO Ocean Line Wind	30
Troubleshooting	30
Installing the VDO Ocean Line Wind	31
Installing the indicating instrument	31
Installing the wind sensor	33
Electrical installation	36
Setting the instrument for wind speed indication	36
System power supply	37
Connecting an analog wind speed indicating instrument	38
Connecting a secondary indicating instrument	40
Key for circuit diagram	41
Cable lengths	41
Technical data	41

**Manual should always be kept
on board!**

Preface

Thank you for selecting an instrument from the VDO Marine program range; a high-quality, state-of-the-art product providing invaluable assistance and safety at sea. Our advanced production methods and the conformance of our products to the relevant quality assurance standards ensure that our products are dispatched in excellent condition.

Please take the time to study this manual carefully. It will tell you all you need to know about the functions of your VDO anemometer system and ensure that it is straightforward and safe to use.

If you have any further queries or problems, please do not hesitate to contact your VDO Kienzle agent who will be pleased to help you.

Yours sincerely
VDO Kienzle Vertrieb und Service GmbH

Safety instructions

Please respect all instructions in this manual.

Please pay particular attention to text marked with this symbol, which indicates an important aspect of system operation and safety.



Using the compass system does not relieve you of the responsibility for your ship, and requires good seamanship. Always rely on your nautical experience for the interpretation of the indicated values.

Safety Instructions for installation:

The anemometer system should be installed by your shipyard or by a specialist.

Adequate working clothes should be worn if you install it yourself. Avoid loose clothing and use a hair net if your hair is long. Clothing and hair may be caught in moving parts.

Remove all metallic or electrically conducting jewelry, such as chains, bracelets, rings, etc. when working on the on-board electrical system.

Disconnect the minus polarity of the battery before starting your work to prevent the risk of a short-circuit. Short-circuits can cause harness fires, battery explosions and damages of other electronic memory systems. Please note that all volatile electronic memories will lose their contents, and will have to be re-programmed if you disconnect the battery.

VDO instruments are not equipped with volatile memories.

Risk of explosion! Run the engine blower for a certain time before starting work in a gasoline engine compartment.

Check for sufficient clearance behind the mounting hole when selecting the location for the indicating instrument. Pre-drill the hole and finish with hole or keyhole saw (respect the safety instructions of the tool manufacturer).

If you must work without disconnecting the power supply, insulated tools should be used.

The electrical outputs of the anemometer system indicating instrument and the cables connected to them must be protected against direct contact or damage. This means that the cables must have a sufficient insulation resistance or voltage rating, and that touching the contact points is prevented.

Adequate measures are taken to ensure that electrically conducting parts of the connected consumers are protected against direct contact. The use of non-insulated wires and contacts is strictly forbidden.

Safety Instructions for maintenance

Anemometer system components can only be repaired by specialists authorized by VDO Kienzle. The VDO LOGIC anemometer system fulfills the applicable safety regulations.

Note: Capacitors in the unit can retain their charge, even if the unit is separated from its power supply.

Check that replacement fuses are of the indicated type and current rating. The use of temporarily repaired fuses or jumpering the fuse holder is strictly forbidden.

The VDO Ocean Line Wind

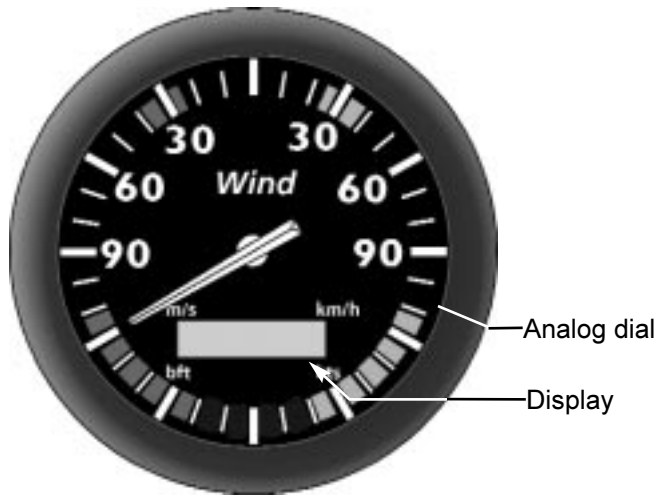

The VDO Ocean Line Wind is a reliable anemometer system designed for use in yachting.

When in operation, the system displays the apparent wind direction on the analog dial. The apparent wind speed is shown on the LCD.

A maximum of 3 additional subsidiary indicating instruments can be connected to the indicating instrument, for example a wind speed indicating instrument.

An NMEA Interface VDO Number N01 610 506 is also available as an accessory. This can be used to transmit data to the VDO LOGIC MAP or to the PC.

Components of the system

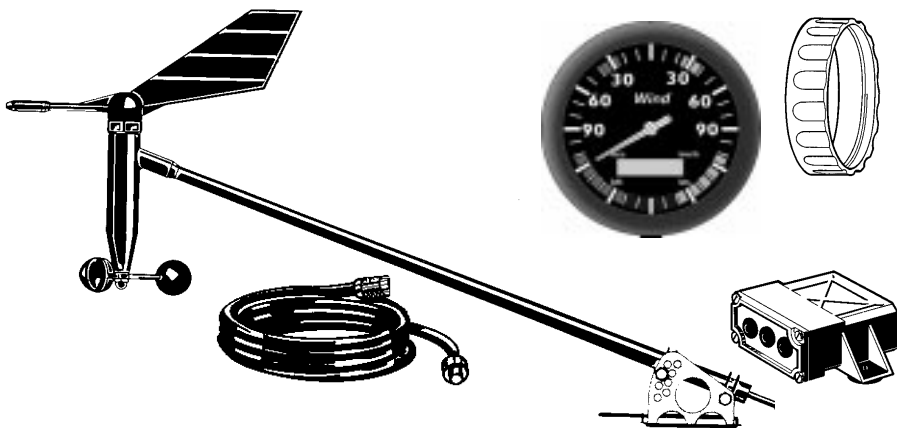

The supplied kit contains:

- Indicating instrument
- Union nut for instrument fixation
- Anemometer sensor with fixation base plate
- Mast cable from sensor to display unit, length 30 m
- Strain relief for mast cable
- Connecting socket
- Product certificate
- Installation and operating instructions

Accessories (must be ordered separately)

- | | | |
|---|---|-------------|
| - | Fixation kit (bracket) | N05 800 792 |
| - | Lighting kit (24 V / 1.2 W) | N05 800 550 |
| - | Analog wind speed indicating instrument | N01 310 502 |
| - | NMEA Interface | N01 610 506 |

Spare parts:

- | | | |
|---|-----------------------------|-------------|
| - | Lighting kit (12 V / 1.2 W) | N05 800 552 |
|---|-----------------------------|-------------|
- Other spare parts are available on request.

Display functions of the VDO Ocean Line anemometer system

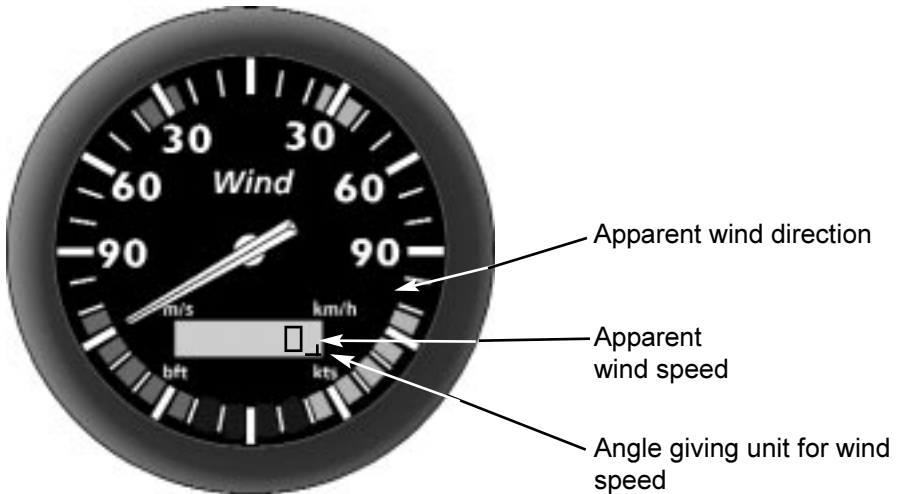

1. Apparent wind direction
The needle on the indicating instrument indicates the apparent wind direction. The colored area on the dial marks the optimum wind angle at which the best possible speed can be expected, either against or with the wind.

2. Apparent wind speed
The wind speed is shown on the LCD in the unit specified during setup (m/s, km/h, bft or kts). The selected unit will be marked on the display with a small angle (in the above illustration, for example, the wind speed will be displayed in knots). On connection to the boat's supply system, the unit in which the wind speed should be displayed in the LCD should be set (see the Installation section).

Maintenance of the VDO Ocean Line Wind

The indicating instrument is maintenance-free. Clean the indicating instrument with a damp, non-fuzzing or anti-static cloth. Do not use cleaning detergents.

The wind sensor does not need any maintenance. Do not oil the sensor bearings, as the oil may gum and attract dirt particles.

The electrical contacts of the socket at the mast footing should be cleaned once per season. Oxidized contacts can lead to system failures.

Troubleshooting

Fault

Cause/ Remedy:

- | | |
|---|---|
| <ul style="list-style-type: none"> - VDO Ocean Line Wind without function
 - Incorrect direction display
 - Incorrect wind speed | <ul style="list-style-type: none"> - Check electrical connections are accordance with the wiring in diagram - Check the on-board voltage, supply voltage is 10.8 to 32 V DC - Check contacts and connections for corrosion or dirt deposits - Check mast cable integrity
 - Sensor offset: Sensor must be mounted exactly in the pointing ahead direction. For a direction of 90°, 180° or 270° the vane must be mounted as described on page 13. - Check contacts and connections for corrosion or dirt deposits
 - Different instrument for wind speed: install an instrument as described on page 16. |
|---|---|

Installing the VDO Ocean Line Wind



Please read the safety instructions on pages 25 and 26 before starting the installation.

Installing the indicating instrument

- Make a hole, diameter 86 mm, at an adequate location.
- Clean the surroundings and remove the chips before inserting the indicating instrument.
- Pass the cable connections to the indicating instrument through the mounting hole and the union nut.
- Place the supplied black rubber washer on the instrument back.
- Connect the cables per wiring schematic to the indicating instrument and insert the instrument into the mounting hole (see "Electrical installation").
- Fix the instrument with the union nut.
Mounting alternative A for wall thicknesses $d = 0.5 \text{ mm to } 6.5 \text{ mm}$
Mounting alternative B for wall thicknesses $d = 6.5 \text{ mm to } 16.5 \text{ mm}$
- Check that the union nut is only tightened hand-tight.

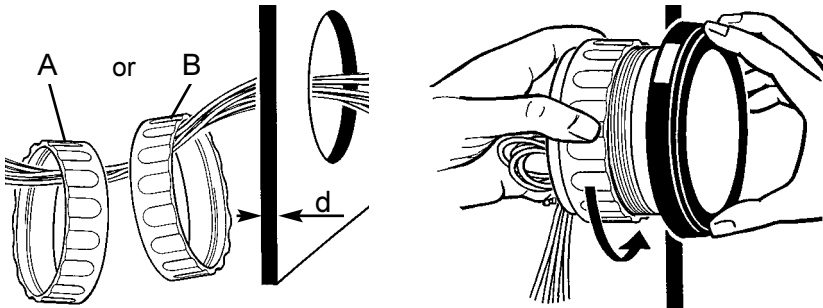

Mount the indicating instrument with threaded studs and bracket (see page 32, top) if strong vibration must be expected at the location of the installation (for instance high-speed boats).

INSTALLATION

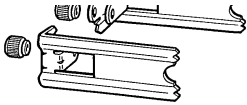

1.5 Nm max.

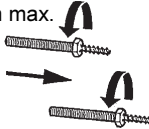

1.5 Nm max.

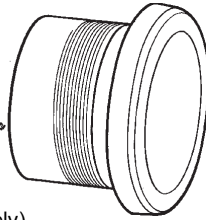

Fixation parts kit N05 800 792 (order separately)

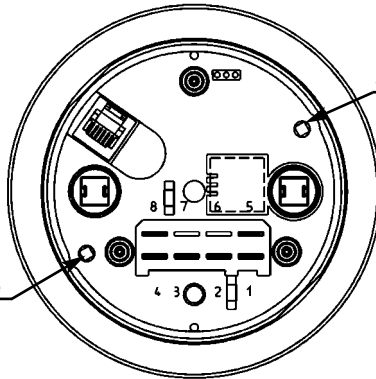

Screw threaded stud in here

Screw threaded stud in here

INSTALLATION

Installing the wind sensor

First, remove the base plate of the wind sensor. Proceed as follows:

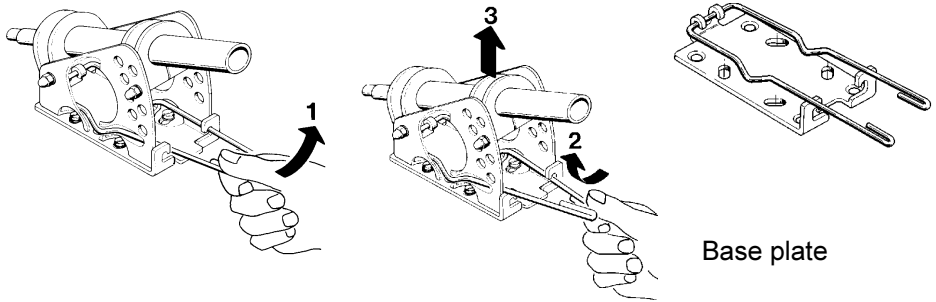

Loosen the spring clip by pushing it down and inward (1), (2), then remove the wind sensor (3).

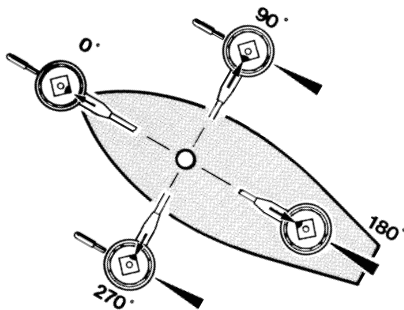

Example:
Starboard sensor orientation

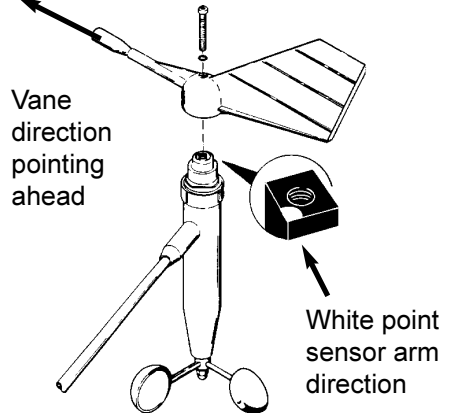

When mounting the base plate, the sensor mounting direction should be pointing ahead (0°) if possible. If this is not possible, other mounting directions can be used (90° , 180° , 270°).

In this case, the vane must be dismantled by loosening the screw. Mount the vane so that the direction is pointing ahead, while the white point indicates the direction of the sensor arm.

INSTALLATION

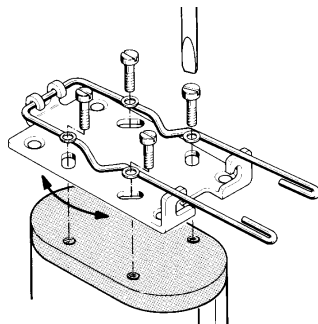

Depending on the structure of the mast, fix the base plate on the mast top, using suitable screws. Rotate the base plate over the oblong holes so that its central axis is parallel to the longitudinal ship axis, or to port or starboard. Inclinations of the mast top can be compensated with the sensor footplate.

Lateral mast mounting of the sensor is also possible.

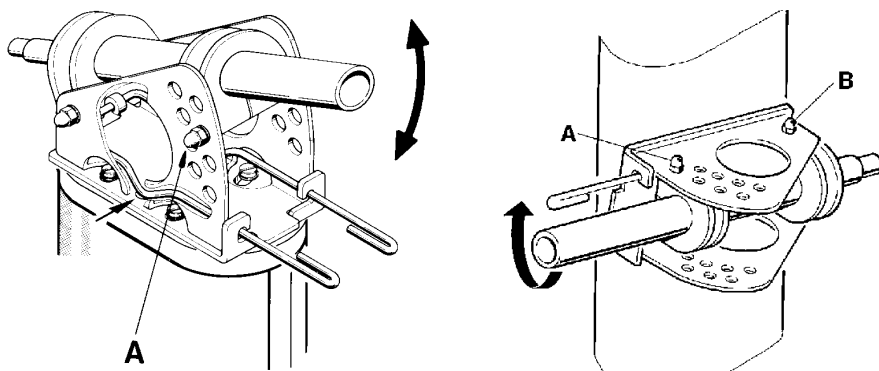

Install the sensor on the base plate. Sensor inclinations can be compensated by changing pin and nut (A). In the case of lateral mast mounting loosen the nuts (A) and (B) and turn the sensor so that it is vertical to the midship axis.

Installing the mast cable

Do not sharply bend the mast cable. Avoid chafing.

Shorten the mast cable to a length of the mast length plus 2 m. Place the strain relief at the point where the cable enters the mast from the top. Use existing empty tubes to protect the mast cable (e.g. from chafing of the rakes), and install it with the mast down if possible.

Install the other end of the mast cable from the indicating instrument to the connecting socket at the foot of the mast.

Installing the connecting socket

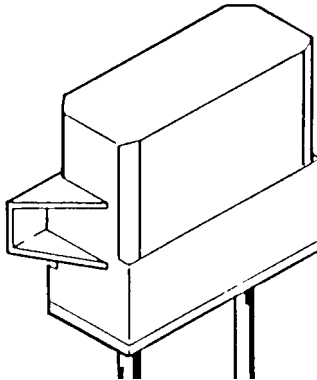

Install the cable socket below deck at the foot of the mast as shown. The socket must be protected against water damage. Make all screw connections with care. The cables shall leave the socket downward.

Connect the 8 wires at both cable ends according to the following table, using the 6-channel terminal board:

Terminal 1	red and pink
Terminal 2	brown
Terminal 3	grey
Terminal 4	yellow
Terminal 5	white
Terminal 6	blue and green

Electrical installation

Setting the instrument for wind speed indication

The VDO Ocean Line WIND is fitted with an LCD, which can display wind speed in m/s, km/h, bft (Beaufort) or kts (Knots). The black angle in one of the four corners of the display shows the instrument which has been selected. The setting can be adjusted as follows:



1. Switch on the power supply.
2. When „UNIT“ appears, switch off the power supply immediately and then switch it on again.
3. Switch the power supply on again, as soon as the needle indicates the desired instrument.

On power up, the instrument shows the text “UNIT” for 5 seconds. Switch off the power supply before this time elapses and switch it on again.

The black needle on the instrument now points to the other units for the wind speed in turn, in a clockwise direction. When it reaches the desired unit, switch the power supply off again.

The unit will be saved in a non-volatile memory and remains saved even after shutdown.

The unit can be adjusted again at any time as described above.

System power supply

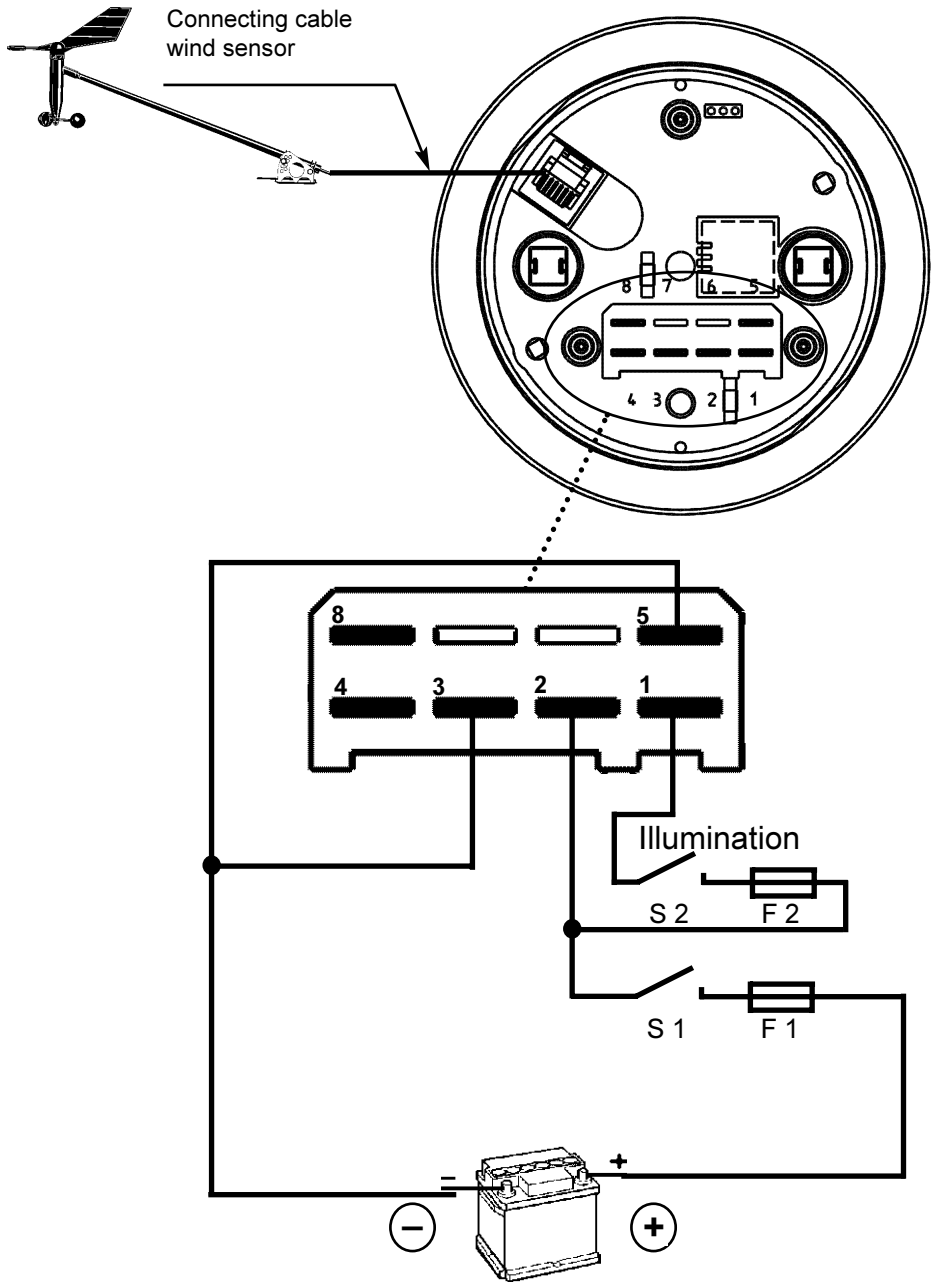

Key for the circuit diagram appears on page 41

Connecting an analog wind speed indicating instrument

An analog wind velocity indicating instrument can be connected to the Ocean Line Wind installation as an accessory. It shows the apparent wind speed.



Mount the wind speed indicating instrument as the main indicating instrument (see page 11). The maximum length of the cable between the main indicating instrument and the wind speed indicating instrument is 10 m.

The power for the wind speed indicating instrument is to be supplied in the same way as for the main indicating instrument (see page 17). The indicating instrument power supply must be switched on at the same time.

INSTALLATION

The main indicating instrument should be connected to the wind speed indicating instrument as shown below.

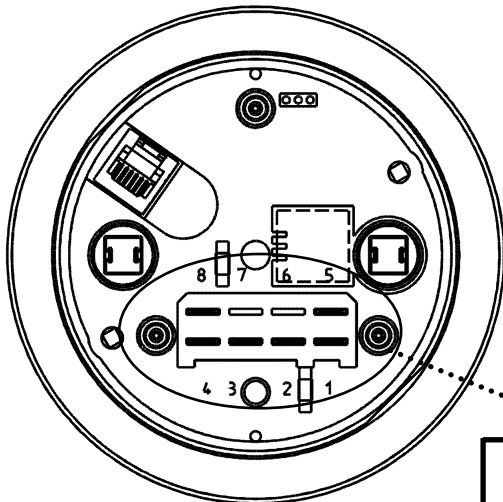

Main indicating instrument or
secondary indicating instrument

Wind speed indicating instrument

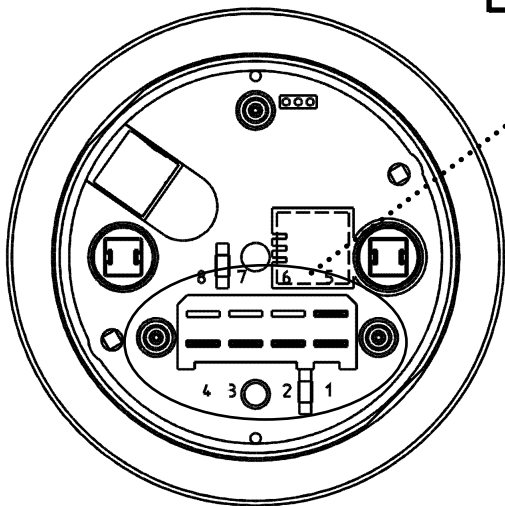
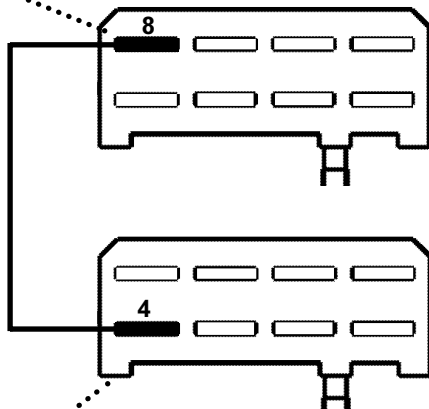

Connecting a secondary indicating instrument

Install the power supply to the second instrument in the same way as for the first one (see page 37). The instrument for indicating wind speed is set in the same way as the main indicating instrument (see page 16).

The power supply of both indicating instruments must be switched on at the same time.

The main and secondary indicating instruments should be connected as shown below.

Up to 3 subsidiary indicating instruments can be connected to the main indicating instrument as well as to each of the secondary indicating instruments.

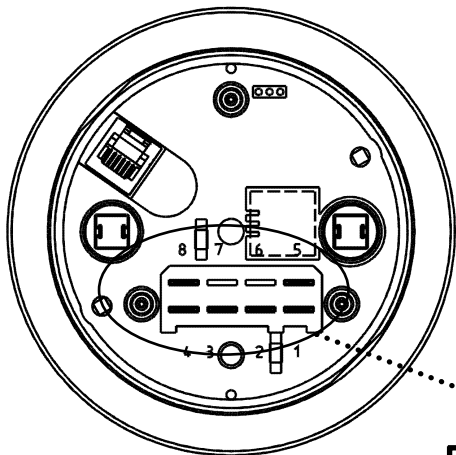

Main indicating instrument

One or more secondary indicating instruments

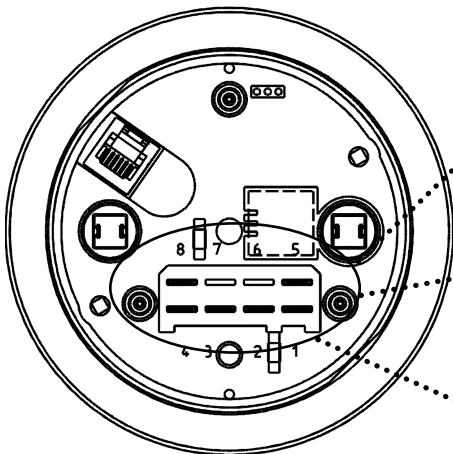

Primary direction ind. inst.

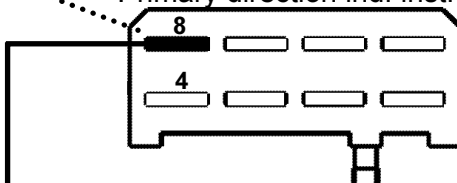

Primary speed indicating inst.

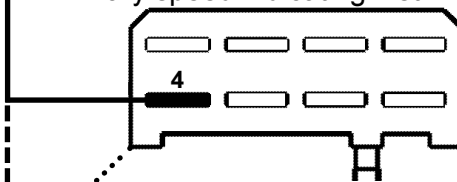

Secondary direction ind. inst.

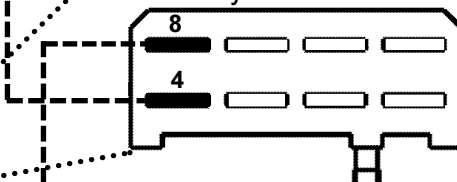

Secondary speed indicating inst.

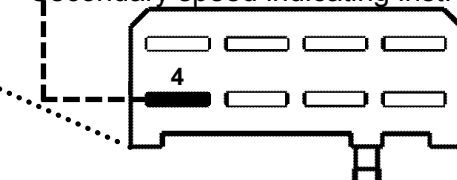

Key for circuit diagram

- S1 On/Off switch for navigation instruments
- S2 On/Off switch for instrument lighting
- F1 Fuse for navigation instruments (5 A)
- F2 Fuse for instrument lighting (5 A)

Recommended cable section: 1.5 mm²

Cable lengths

Wind sensor - indicating instrument	20 m max.
Indicating instrument - second instrument	10 m max.
Second instrument - third instrument	10 m max.

Technical data

Measuring principle:	Vane with inductive transmission, Cup anemometer with Hall chip
Accuracy	direction $\pm 3^\circ$ speed ± 2 km/h (0...60 km/h)
Resolution:	Direction 1° , Speed 1 km/h
Supply voltage	10.8 to 30 V DC
Current consumption:	about 140 mA at 12 V DC without lighting about 300 mA with lighting
Operating temperature	-10 to +60°C
Type of protection	IP 65 at front per IEC 529
EMC protection	CE: EN 50081-1, EN 50082-1
Dimensions:	Indicating instrument: Front ring diam...: 105 mm Installation diam...: 86 mm Installation depth (with union nut): 56 mm Installation depth (with bracket): 90 mm Compass sensor: See figure page 37

VDO
Ocean Line

Wind

06/99 -

08 601 209

VDO Kienzle Vertrieb und Service GmbH
Kruppstrasse 105
D-60388 Frankfurt am Main

Tel.: +49 (0)69 40805-0
Fax: +49 (0)69 40805-177
e-mail: vdomarine@vdokienzle.com
Internet: www.vdokienzle.com/marine